

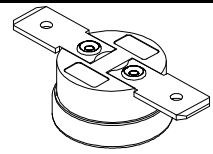

1/2" Disc Type Thermostat
Thin Type

Type **11EN**



Dimensions

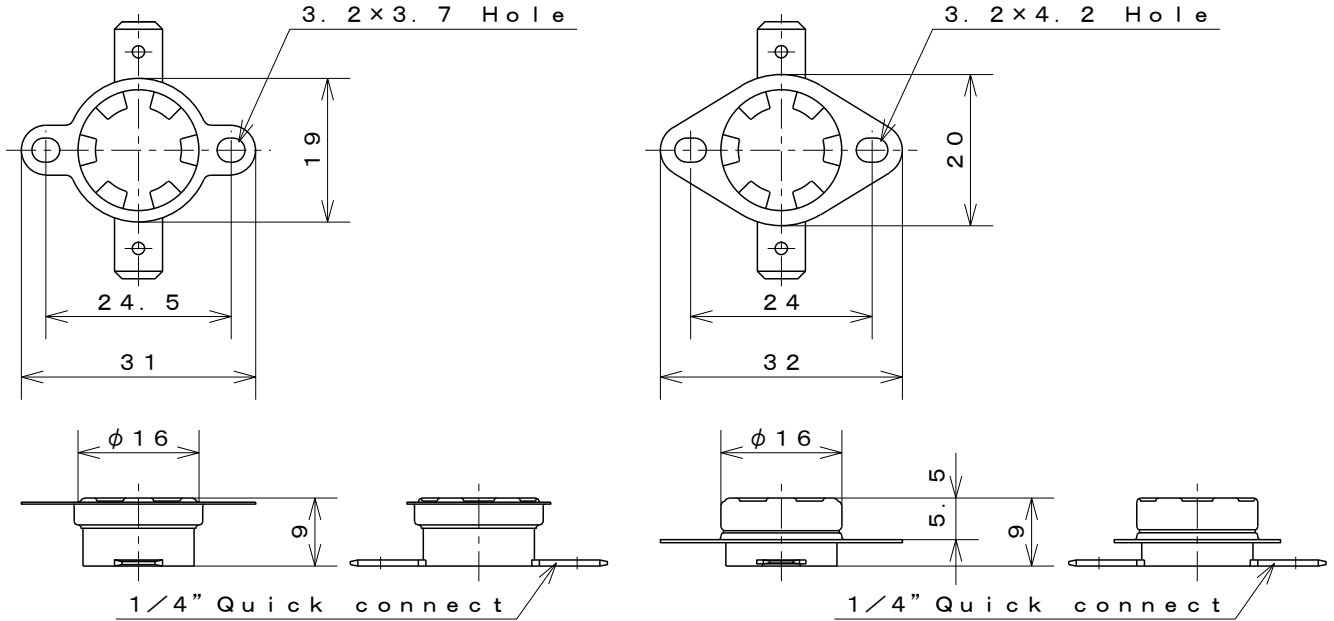

Materials of parts

Part	Material
Cap	Aluminum Copper Stainless steel
Case	Phenolic resin
M.arm	Beryllium Copper alloy
Terminals	Brass
Bracket	Stainless steel
Contacts	Silver-Nickel alloy

Structure

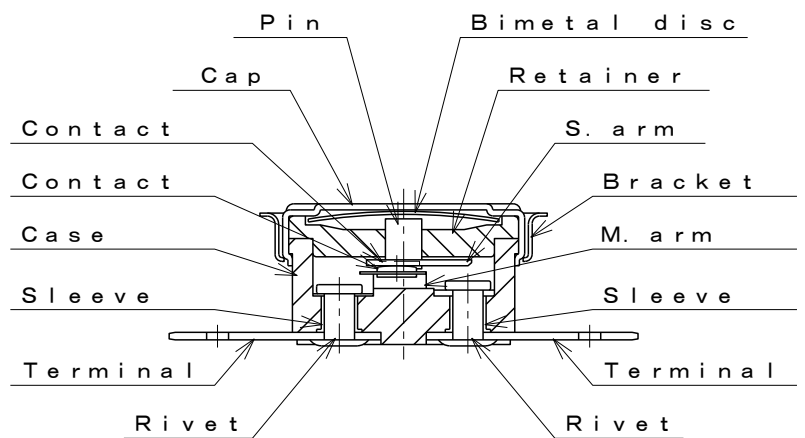

Specification

★Compliance with RoHS Directives

Item	Specification
1. Basic features	SPST Automatic reset
2. Operation	A : Contacts open on temperature rise B : Contacts close on temperature rise
3. Electrical rating	AC125V/15A AC250V/10A
4. Calibration method	Hot & cold air circulation system
5. Temperature rating	Operating temperature Max. 150°C
6. Insulation resistance	Not less than 1,000MΩ/DC500V
7. Dielectric strength	Not less than AC1,500V/1min. or AC1,800V/1sec.

Standard

UL 873	UL File	No. E43273
CSA C22.2 No. 24	CSA Report	No. LR67165
DIN EN 60730-1, -2-9	VDE Licence	No. 40004286

